

## Grow Your Own Greens with Salad Tables & Salad Boxes

### Introduction

Do you love the idea of eating home-grown salads from April through November? This fact sheet will tell you how to build and use two new types of container gardens that will enable you to produce fresh, flavorful greens close to your backdoor.

The Salad Table is essentially a shallow wooden frame with a large surface area and a mesh bottom that allows water to drain. You can attach legs of any length you desire or set it on saw horses or other supports. It is portable, versatile, easy and inexpensive to build, and terrific for gardeners of all ages, sizes, and abilities. The Salad Table can be moved to capture sunlight in spring and fall and avoid the sun and high heat of summer. Best of all, you can garden comfortably at waist level and avoid problems with rabbits and groundhogs. The Salad Box is the baby version of the Salad Table and works especially well for kids and folks with small spaces.

### Building a Salad Table (33" wide X 58" long):

- Untreated, framing lumber:
  - Two 2 X 4s, 10' long
  - Two 2 X 4s, 12' long
- 3" galvanized wood screws
- 3/8" staples
- Roofing nails
- 3' X 5' roll of 1/2" mesh hardware cloth  
(This is a galvanized wire mesh that comes in a roll.)
- 3' X 5' roll of aluminum window screening

### Tools:

Handsaw	Square,
Hammer	Tin snips,
Drill	Staple gun
#2 Phillips screw bits	Leather gloves
Tape measure	

### Directions:

- Cut (2) 58" sections from a 10' 2 X 4 (long sides)
- Cut (4) 30" sections from the other 10' 2 X 4 (cross pieces)
- Cut (4) 32.5" sections from a 12' 2 X 4 (inside support legs)
- Cut (4) 36" sections from the other 12' 2 X 4 (outside legs)

- Attach the long sides (58") to the cross pieces (30") using the 3" galvanized screws (2 screws/cross piece.) The two interior cross pieces are attached 18 3/4" from each end of the long piece (this makes for three roughly equal sections.)
- Center the window screen on the outside bottom of the frame. Two people are required to stretch it taught and staple it to the frame bottom and sides using a staple gun.
- Center the hardware cloth over the window screen, pull it taught, and staple it to the frame bottom. Nail roofing nails around the frame for added support. Now make a diagonal cut with tin snips at each corner of the hardware cloth. This enables you to fold it up and onto the sides of the frame where it can be stapled and nailed.
- Build four sturdy legs by attaching each of the 32 1/2" legs to a 36" leg using the 3" galvanized wood screws. (Figure 1)
- The table will rest on the shorter piece of each 2-piece leg. Attach the legs, 4 inches in from the four corners, by driving three 3" screws through the top of each leg and into the long side of the frame. (Figure 2)

### Tips:

- 1) **Drill pilot holes with an 1/8" drill bit before driving in the galvanized screws.**
- 2) **Use a wood rasp to clean up rough edges after cutting your wood pieces.**
- 3) **Cover the edge of the window screen and hardware cloth on all four sides of the frame using duct tape or molding.**

## Alternative construction methods:

- 1) The Salad Table can be made any width and length as long as the weight of the growing media, water, and plants can be supported.
- 2) You can substitute 10d galvanized nails for the screws. If you prefer, you can have your lumber yard or store make the required lumber cuts. You can substitute 2 X 6 boards for a deeper growing bed (good for snap beans), or 2 X 8 boards (good for peppers, determinate-type tomatoes, and bush cucumbers.)
- 3) Legs can be made from 4 X 4s (with a 1 1/2" X 3 1/2" notch cut out to support the frame) or you can set the frame on two sawhorses, or other supports. Attach casters to the legs to make it mobile!
- 4) You can eliminate the hardware cloth and just use window screen for the bottom. Be sure to attach two 1 X 4 boards, each 58" long, over the window screen to prevent the bottom from sagging.
- 5) If you just want a hardware cloth bottom with no window screen, you'll need to cover the bottom of each section with newspaper or a paper grocery bag to prevent the growing media from sifting out. Or use a plastic bag with small holes cut with a knife for drainage.
- 6) You could make the frame with one divider instead of two.
- 7) For a more beautiful Salad Table, paint it with an exterior latex paint.

## Building a Salad Box:

- Cut one 6' pine or cedar board (1 X 4) into four pieces- (2) 15" pieces and (2) 21" pieces.
- Use 1 5/8" galvanized screws to attach one long piece to the two short pieces.
- Repeat with other long piece and then attach window screening and 1/4" hardware cloth to the bottom with a staple gun. Attach handles if you like.
- This weighs about 12-15 lbs. when filled with moist growing medium and plants.

## Getting Started: Location, Tools, Supplies

Location is one of the keys to getting the most from your new container gardens. Select a convenient spot close to your home and a water source. The ground should be level; otherwise water will pool in the corners of the frame. Leaves, twigs, flowers and other debris will land on the Salad Table or Salad Box if located under trees. If possible, select a sunny spot for April-June 15, move your garden to a shady spot from June 15-Sept. 15, and then back to full sun from mid-Sept. through November. Salad greens will grow best with maximum sunlight during the cooler spring and fall months and minimum sunlight during the hottest summer months.

The only items you'll need are seeds, growing media, fertilizer, scissors, and a watering can, or hose and nozzle. Another useful tool is an inexpensive hand seeder that will help you evenly space small seeds.

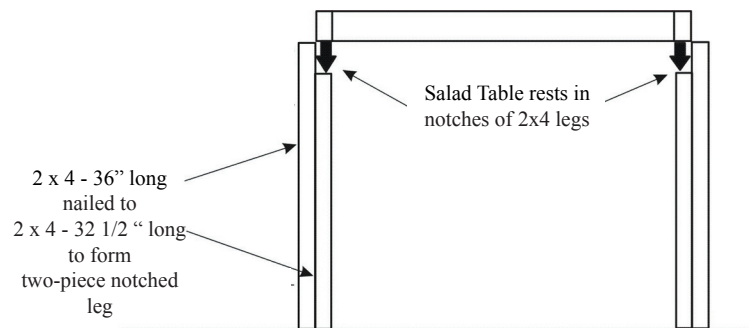

Figure 1. Salad Table on 2 x 4 Leg (End View)

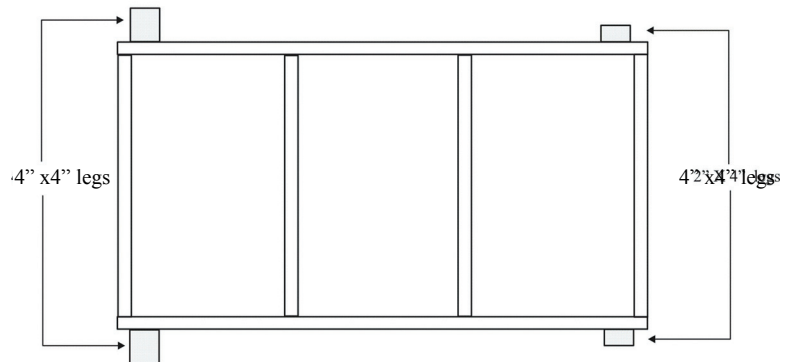

Figure 2. Top View of Salad Table

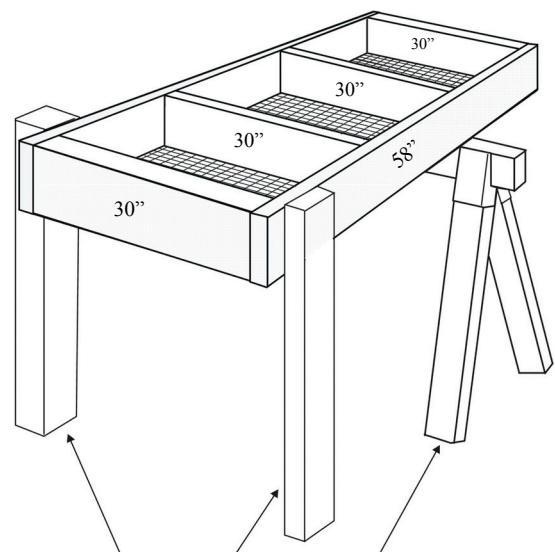
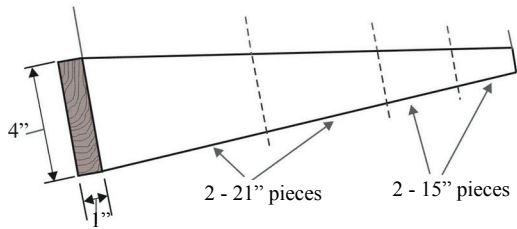
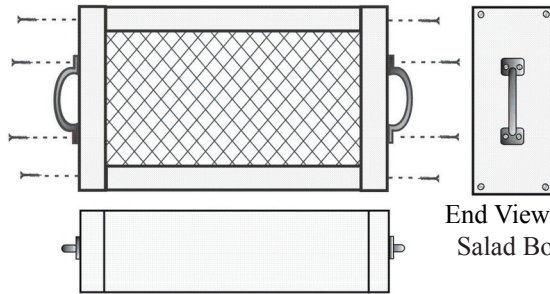

Figure 3. 4 x 4 legs or 2 x 4 legs or sawhorse support options shown in perspective view

## Salad Box



Top View of Salad Box



End View of Salad Box

Side View of Salad Box

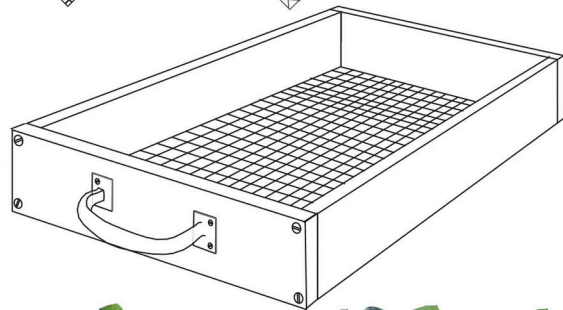
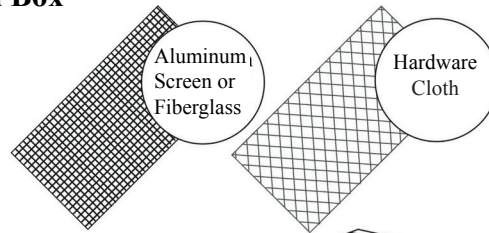

## What Can I Grow??

Broccoli family- arugula, kale, mustard greens, radish, cress, broccoli raab, mizuna, kyona, komatsuna  
 Beet family- spinach, chard, orach, beets  
 Lettuce family- lettuces, endive, escarole, chicory  
 (Note: 'Deer Tongue', 'Red Sails', 'Bronze Arrow', 'Jericho', and oak leaf types are more heat tolerant)  
 Parsley family- chervil, parsley, cilantro  
 Mint family- basil, thyme, anise hyssop  
 Other crops- leafy amaranth (callaloo), sorrel, purslane, claytonia (miner's lettuce), corn salad (mache)

## Growing Media

Your choice of growing media is very important because your salad greens are dependent on a relatively small volume of growing medium (only 3" deep!) Unlike their cousins growing in garden soil, containerized plant roots cannot grow around obstacles or mine the soil far and wide for nutrients and water. Growing medium has three main functions- 1) supply roots with nutrients, air, and water, 2) allow for maximum root growth, and 3) physically support the plant. Your growing media should have large particles with large pore spaces between the particles. This will make it light and fluffy (well-aerated) encouraging fast seed germination, strong root growth, and good water drainage.

- Fill your table or box with 100% soil less growing media (contains peat moss, perlite, and vermiculite), 100% high quality compost, or a combination of the two.
- Always pre-moisten soil-less mixes containing sphagnum peat moss.
- Soil-less growing media will settle quite a bit because of the large pores.
- Avoid garden soil because it is too dense and contains weed seeds.
- It's best not to re-use your growing media a second season

for the table or box. Weathering will cause particle size to decrease, leading to poor aeration and inhibited root growth. Instead, spread the old growing media around garden plants.

## Fertilizing

Commercial growing media and compost do not contain enough nutrients to produce high yields of salad greens over a growing season. Incorporate a dry fertilizer into the growing media- one that contains nitrogen, phosphorous, and potassium. Examples are slow-release fertilizers (Osmocote), cottonseed meal, and chicken manure products that have been composted or heat-treated to kill human pathogens. These products will provide nutrients for many weeks depending on the nutrient content, weather, and crops grown. Always follow label directions. Liquid fertilizers, like compost tea, kelp and fish products, and soluble "plant foods", are also suitable but will need to be applied more frequently than the dry fertilizers.

## How to Plant

- Fill your frames with growing media and level it off (don't pack it).
- Make shallow furrows across the length of a section. Furrows are spaced 4"-5" apart.
- Sow seeds 1" apart in the row and then cover very lightly with growing media.
- The seeds of most salad greens will germinate in 2-4 days. It will take longer when growing media temperature is below 50° F or above 80° F.
- A floating row cover can be draped over the frames to promote faster plant growth in spring and fall. The cover raises temperature and humidity and protects plants from wind damage.

## Watering

Salad Tables require about one gallon of water daily, either from a watering can or a nozzle attached to a hose that delivers a soft water spray. Less water is required during cool, overcast weather. Never use hot water from a container that has been sitting out in the sun.

## Continuous Planting and Harvesting

- Sow salad greens continuously from late March through the first week in October. Basil and thyme should be sown in mid-May.
- Salad greens will grow 4-6 inches in height in 25-40 days, depending on the crop, time of the season, and weather conditions.

- The “cut-and-come-again” harvesting method is very efficient. Use scissors to cut all plants close to the growing media level. The plants will re-grow and can be harvested again. Sometimes it is possible to get a third cutting.
- One Salad Table will produce 16-32 oz. of greens from a single cutting.
- When plants become weak, bitter, and unproductive they can be “turned under” or pulled out by hand.
- The growing media can be replenished and fertilized, if necessary, and the next crop is sown. Each section of the Salad Table can produce three crop cycles between late March and November.
- An alternative harvesting method is to thin plants so they are spaced 4-6 inches apart and harvest outer leaves or entire plants.

## Some Recommended Seed Catalogs for Salad Greens

Abundant Life Seeds  
PO Box 157  
Saginaw, OR 97472-0157  
www.abundantlifeseeds.com  
541.757.9606

The Cook's Garden  
PO Box C5030  
Warminster, PA 18974  
www.cokksgarden.com  
800.457.9703

Evergreen Y.H. Enterprises  
PO Box 17538  
Anaheim, CA 92817  
www.evergreenseeds.com  
714.637.5769

FEDCO  
PO Box 520  
Waterville, ME 04903-0520  
www.fedcoseeds.com  
207.873.7333

High Mowing Organic Seeds  
P.O. Box 180  
Wolcott, VT 05680  
www.highmowingseeds.com  
802.472.6174

Johnny's Selected Seeds  
955 Benton Ave.  
Winslow, ME 04901-2601  
www.johnnyseeds.com  
877.564.6697

Kitazawa Seed Co.  
PO Box 13220  
Oakland, CA 94661-1860  
www.kitazawaseed.com  
510.595.1188

Kitchen Garden Seeds  
23 Tulip Drive, PO Box 638  
Bantam, CT 06750-0638  
www.kitchengardenseeds.com  
860.567.6086

D. Landreth Seed Co.  
650 N. North Point Rd.  
Baltimore, MD 21237  
www.landrethseeds.com  
800.654.2407

Nichols Garden Nursery  
1190 Old Salem Rd.  
Albany, OR 97321-4580  
www.nicholsgardennursery.com  
800.422.3985

Ornamental Seeds  
5723 Trowbridge Way  
San Jose, CA 95138  
www.ornamentaledibles.com  
408.528.7333

Pinetree Garden Seeds  
PO Box 300  
New Gloucester, ME 04260  
www.superseeds.com  
207.926.3400

Seed Savers Exchange  
3076 North Winn Rd.  
Decorah, IA 52101  
www.seedsavers.org  
319.382.5990  
Seeds from Italy  
P.O. Box 149  
Winchester, MA 01890  
www.growitalian.com  
781.721.5904

Seeds of Change  
PO Box 15700  
Santa Fe, NM 87592-1500  
www.seedsofchange.com  
888.762.7333

Southern Exposure Seed Exchange  
PO Box 460  
Mineral, VA 23117  
www.southernexposure.com  
540.894.9480

Territorial Seed Co.  
PO Box 158  
Cottage Grove, OR 97424-0061  
www.territorialseed.com  
800.626.0866

**Author:** Jon Traunfeld,  
Regional Specialist, Maryland  
Cooperative Extension, 3//07  
**Illustrator:** Don Wittig,  
Maryland Master Gardener

**Have a home or garden question?**

**Call the Home and Garden  
Information Center  
1-800-342-2507**

**(MD residents only)**

**410-531-1757 (Outside MD)**

<http://www.hgic.umd.edu>

I hope you are now curious enough to build a Salad Table or Salad Box. If you do, please let me know about your experiences. This is a new project and your comments and observations will help me improve our building plans and recommendations. Contact me by phone at 1.800.342.2507; or by e-mail at [jont@umd.edu](mailto:jont@umd.edu).

For more information on container vegetable gardening, including the Salad Table and Salad Box, please visit the Maryland Master Gardener website; click “Garden Topics” and then “Container Vegetable Gardening.”